



INSTALLATION OPTIONS AND DIMENSIONS

Above ground epoxy-fix	550mm L × 440mm W × 1050mm H
Above ground bolt-fix	550mm L × 440mm W × 1050mm H
Below ground bolt-fix	550mm L × 440mm W × 1200mm H

CAPACITY

65 litres - Removable galvabond steel liner with handles.

MATERIALS AND FINISHES

Frame, door and back panel - Clear anodised aluminium.

Body - Powder coated aluminium.

Hinge and tool operated security cam latch - Stainless Steel.

OPTIONAL ASHTRAY

Lift to release contents into bin - Stainless steel with satin polish.

OPTIONAL GRAPHICS

Signage or other graphics can be applied using client's artwork.

Design is full-colour printed onto Avery MPI 1005 Supercast series vinyl wrap, with Avery DOL 4300 Anti Graffiti polyester overlamine.

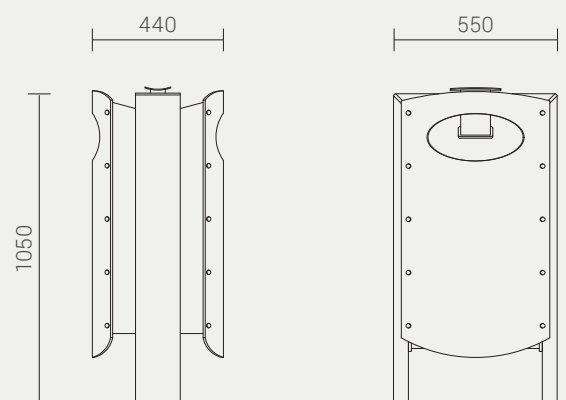

Designed by Cox Urban Furniture

E: info@coxurbanfurniture.com.au
WEB: coxurbanfurniture.com.au

Copyright © 2020 Cox Urban Furniture.

COX
URBAN FURNITURE

Distributed by Burdens Australia

HEAD OFFICE - WA

Burdens Australia
P: (08) 9302 4077
E: sales@burdens.net.au

11 Profit Pass
Wangara WA 6065

QUEENSLAND

Burdens Australia
P: (07) 3287 5166
E: qldsales@burdens.net.au

VICTORIA

Burdens Australia
P: (03) 9330 2752
E: vic-sales@burdens.net.au

INTERNATIONAL

Environmental Street Furniture
P: 0011 44 845 606 6095
E: sales@worldofesf.com

ESF Global Sales Office
67 Church Road
Newtownabbey, Belfast BT36 7LS
Northern Ireland