

BOLLARD - REMOVABLE

URB:BLD 101R

URBAN EDGE
RANGE



INSTALLATION OPTIONS AND DIMENSIONS

Below ground bolt-fix	150mm L x 150mm W x 1300mm H
Below ground in-situ poured concrete.	150mm L x 150mm W x 1550mm H

REMOVABLE OPERATION

The tube projecting from the underside of the bollard sleeves into the separate in-ground base assembly. When the bollard is removed, the hinged hasp for the padlock covers the rectangular hole in the paving.

Padlock is not included.

MATERIALS AND FINISHES

Bollard - Clear anodised aluminium with cast aluminium corners.

In-Ground Base Assembly - Steel with exposed hot-dip galvanised finish.

DECORATIVE USE ONLY

This bollard is not designed as a security barrier to protect people or property from vehicle impact and must not be used for this purpose.

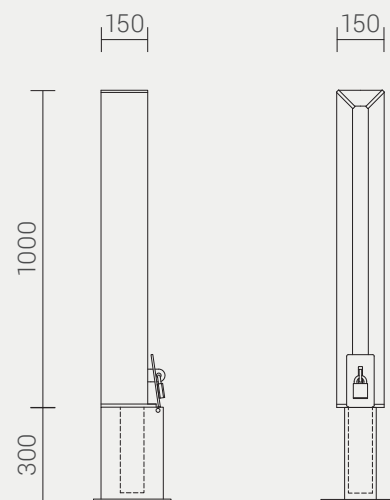

Designed by Cox Urban Furniture

E : info@coxurbanfurniture.com.au
WEB : coxurbanfurniture.com.au

Copyright © 2020 Cox Urban Furniture.

COX
URBAN FURNITURE

Distributed by Burdens Australia

HEAD OFFICE - WA

Burdens Australia
P : (08) 9302 4077
E : sales@burdens.net.au

11 Profit Pass
Wangara WA 6065

QUEENSLAND

Burdens Australia
P : (07) 3287 5166
E : qldsales@burdens.net.au

VICTORIA

Burdens Australia
P : (03) 9330 2752
E : vic-sales@burdens.net.au

INTERNATIONAL

Environmental Street Furniture
P : 0011 44 845 606 6095
E : sales@worldofesf.com

ESF Global Sales Office
67 Church Road
Newtownabbey, Belfast BT36 7LS
Northern Ireland