

DRINKING FOUNTAIN - WHEELCHAIR ACCESSIBLE

PMD:DKF-1A

PROMENADE
RANGE



INSTALLATION AND DIMENSIONS

Above ground bolt-fix to footing and wall face 740mm L × 500mm W × 760mm H

Plumber to connect the downpipe to waste water, and the internal flexible stainless steel hose to the fresh water supply. Connections are concealed behind a semi-circular panel in the base assembly.

MATERIALS AND FINISHES

Base and support arms - Powder coated aluminium.

Domed insert in base - cast exposed aggregate concrete.
Standard finish 'Gunmetal Grey'. Colour can be customised to compliment the surrounding paving.

BOWL AND FITTINGS OPTIONS

Cast high-silicon aluminium bowl with satin chromed push-button bubbler, grate and downpipe.

Cast gunmetal-bronze bowl with patinated brass push-button bubbler, grate and downpipe.

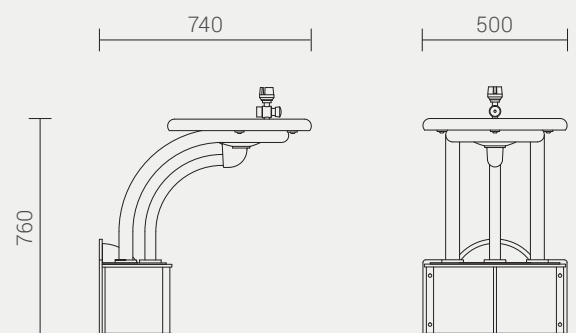

Designed by Cox Urban Furniture

E: info@coxurbanfurniture.com.au
WEB: coxurbanfurniture.com.au

Copyright © 2020 Cox Urban Furniture.

COX
URBAN FURNITURE

Distributed by Burdens Australia

HEAD OFFICE - WA

Burdens Australia
P: (08) 9302 4077
E: sales@burdens.net.au

11 Profit Pass
Wangara WA 6065

QUEENSLAND

Burdens Australia
P: (07) 3287 5166
E: qldsales@burdens.net.au

VICTORIA

Burdens Australia
P: (03) 9330 2752
E: vic-sales@burdens.net.au

INTERNATIONAL

Environmental Street Furniture
P: 0011 44 845 606 6095
E: sales@worldofesf.com

ESF Global Sales Office
67 Church Road
Newtownabbey, Belfast BT36 7LS
Northern Ireland