

# DRINKING FOUNTAIN - WHEELCHAIR ACCESSIBLE PMD:DKF-1

PROMENADE  
RANGE



## INSTALLATION AND DIMENSIONS

**Above ground bolt-fix** 975mm L × 500mm W × 760mm H

Plumber to connect the downpipe to waste water, and the internal flexible stainless steel hose to the fresh water supply. Connections are concealed behind a semi-circular panel in the base assembly.

## MATERIALS AND FINISHES

Base and support arms - Powder coated aluminium.

Domed insert in base - cast exposed aggregate concrete.  
Standard finish 'Gunmetal Grey'. Colour can be customised to compliment the surrounding paving.

## BOWL AND FITTINGS OPTIONS

Cast high-silicon aluminium bowl with satin chromed push-button bubbler, grate and downpipe.

Cast gunmetal-bronze bowl with patinated brass push-button bubbler, grate and downpipe.

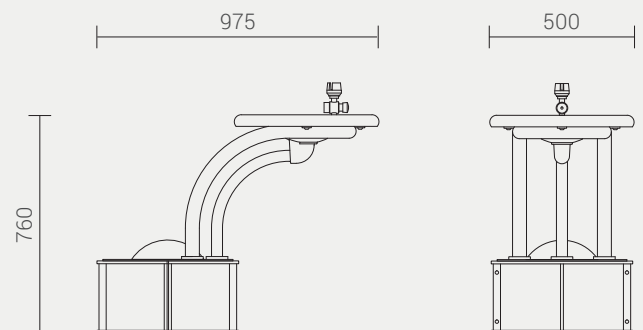

Designed by Cox Urban Furniture

E: [info@coxurbanfurniture.com.au](mailto:info@coxurbanfurniture.com.au)  
WEB: [coxurbanfurniture.com.au](http://coxurbanfurniture.com.au)

Copyright © 2020 Cox Urban Furniture.

**COX**  
URBAN FURNITURE

Distributed by Burdens Australia

**HEAD OFFICE - WA**

Burdens Australia  
P: (08) 9302 4077  
E: [sales@burdens.net.au](mailto:sales@burdens.net.au)

11 Profit Pass  
Wangara WA 6065

**QUEENSLAND**

Burdens Australia  
P: (07) 3287 5166  
E: [qldsales@burdens.net.au](mailto:qldsales@burdens.net.au)

**VICTORIA**

Burdens Australia  
P: (03) 9330 2752  
E: [vic-sales@burdens.net.au](mailto:vic-sales@burdens.net.au)

**INTERNATIONAL**

Environmental Street Furniture  
P: 0011 44 845 606 6095  
E: [sales@worldofesf.com](mailto:sales@worldofesf.com)

ESF Global Sales Office  
67 Church Road  
Newtownabbey, Belfast BT36 7LS  
Northern Ireland