

## ENCLOSURE FOR 240 LITRE WHEELED LITTERBIN

# PKL:EWL-2

**PARKLINE**  
RANGE



### INSTALLATION OPTIONS AND DIMENSIONS

<b>Above ground bolt-fix</b>	800mm L x 800mm W x 1310mm H
<b>Below ground bolt-fix</b>	N/A

### CAPACITY

1 x 240 litre wheeled litterbin - Not included.

### MATERIALS AND FINISHES

Body, door and back panel - Powder coated aluminium.

Rain shield and litter entry surround -  
Stainless steel with satin polish.

Hinge and tool operated security cam latch - Stainless Steel.

### OPTIONAL GRAPHICS

Signage or other graphics can be applied using client's artwork.

Design is full-colour printed onto Avery MPI 1005 Supercast series vinyl wrap, with Avery DOL 4300 Anti Graffiti polyester overlamine.

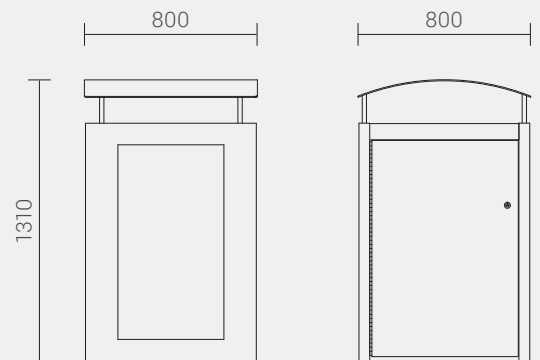

Designed by Cox Urban Furniture

E: [info@coxurbanfurniture.com.au](mailto:info@coxurbanfurniture.com.au)  
WEB: [coxurbanfurniture.com.au](http://coxurbanfurniture.com.au)

Copyright © 2020 Cox Urban Furniture.

**COX**  
URBAN FURNITURE

Distributed by Burdens Australia

**HEAD OFFICE - WA**

Burdens Australia  
P: (08) 9302 4077  
E: [sales@burdens.net.au](mailto:sales@burdens.net.au)

11 Profit Pass  
Wangara WA 6065

**QUEENSLAND**

Burdens Australia  
P: (07) 3287 5166  
E: [qldsales@burdens.net.au](mailto:qldsales@burdens.net.au)

**VICTORIA**

Burdens Australia  
P: (03) 9330 2752  
E: [vic-sales@burdens.net.au](mailto:vic-sales@burdens.net.au)

**INTERNATIONAL**

Environmental Street Furniture  
P: 0011 44 845 606 6095  
E: [sales@worldofesf.com](mailto:sales@worldofesf.com)

ESF Global Sales Office  
67 Church Road  
Newtownabbey, Belfast BT36 7LS  
Northern Ireland